



## Repair Splicing System



**Dextra**



## Product features

The RepairGrip system is a portable system designed to splice bars in situ. It is a simple and proven method to splice bars that did not have their end shop-prepared.

The RepairGrip sleeve is swaged onto the bar ends by an hydraulic tool powered by a separate power unit. The resulting connection guarantees a tensile strength of at least 125% of the nominal yield strength of reinforcing bars grade 500 MPa.

RepairGrip splices are butt-to-butt splices that are suitable to both tension and compression applications.

## Benefits

For repair or retrofit works.

- Fits any cold shear cut bar end.
- No reduction of the cross section area of the bar.
- All sleeves are individually marked allowing full traceability of material origin and manufacturing batch.
- Manufactured under quality assurance ISO 9001.

## Dimensions

Approximate dimensions in millimeters

Product code	Bar diameter (mm)	Sleeve dimensions			
		O.D. (mm)	I.D. (mm)	L (mm)	Weight (kg)
FPOT1200001	12	24	14	100	0.25
FPOT1600001	16	32	20	100	0.40
FPOT2000001	20	38	24	100	0.45
FPOT2200001	22	40	26	150	0.85
FPOT2500001	25	45	30	160	1.10
FPOT2800001	28	53.5	34	130	1.40
FPOT3200001	32	57	38	180	2.00
FPOT3600001	36	63	43	180	2.60
FPOT4000001	40	70	48	250	3.70

*Note: The information in this catalogue is considered up to date at the time of publication. We reserve the right to make technical and design changes at any time.*

*Dextra shall not accept liability for the accuracy of the information in this publication or for any printing errors.*

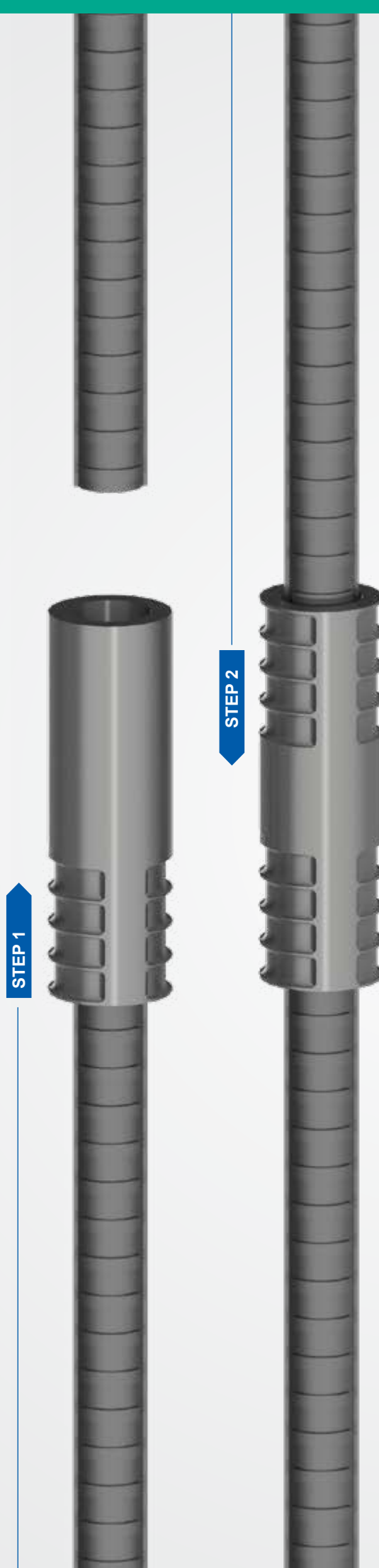

## Minimum bar spacing

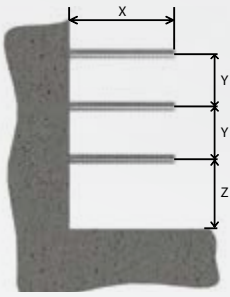

Start by swaging the bar that is closer to the floor or adjacent wall.

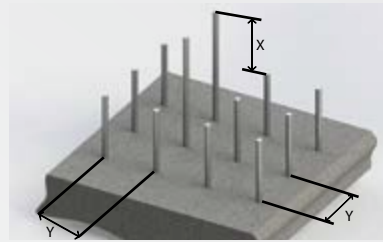

Clustered bars can be spliced if they are staggered and if the central ones are the longest.

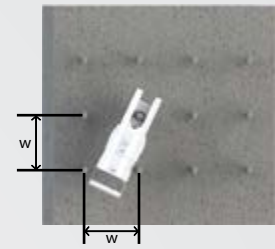

If clustered bars are not staggered, the required spacing is wider so that the swaging tool can reach the central bars.

Bar diameter (mm)	12	16	20	22	25	28	32	36	40
Hydraulic tool model	DMG650-2				DMG800-1 DMG800-2				
X	150	150	150	170	170	160	160	190	220
Y	95	95	95	100	100	110	110	120	120
Z	90	90	90	90	90	90	90	100	100
W	230	230	230	230	230	230	230	250	250

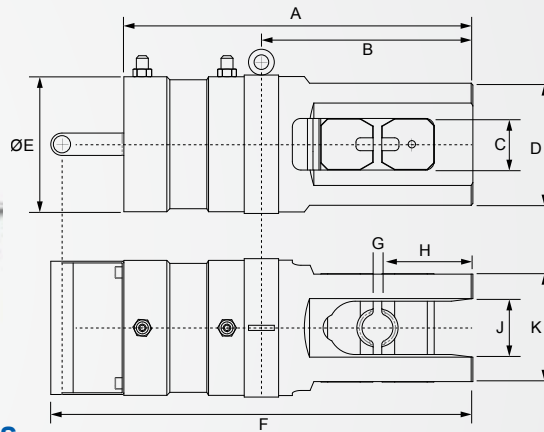

## Hydraulic tool dimensions

Model	A	B	C	D	E	F	G	H	J	K
DMG650-1	430	270	55	116	152	458	35	120	66	116
DMG650-2	405	250	60	142	157	490	32	106	65	125
DMG800-1	440	280	60	148	167	530	52	118	73	145
DMG800-2	440	282	60	148	182	526	37	102	73	145

Diameter (mm)

## Operating data

Bar diameter (mm)	Hydraulic pressure			Number of grips per bar end	Engagement length (mm)	Hydraulic tool model	Weight of Hydraulic jack (Kg)
	(MPa)	(bar)	(PSI)				
12	30	300	4,350	3	45	DMG650-2	42
16	40	400	5,800	3	45	DMG650-2	42
20	45	450	6,530	3	45	DMG650-2	42
22	50	500	7,250	4	60	DMG650-2	42
25	60	600	8,700	4	60	DMG650-2	42
28	65	650	9,430	4	60	DMG650-2	42
32	65	650	9,430	5	75	DMG650-2	42
36	80	800	11,60	6	75	DMG800-1	50
	63.5	635	9,210	6		DMG800-2	50
40	80	800	11,600	8	88	DMG800-1	50
	63.5	635	9,210	8		DMG800-2	50

## Applications



## Installation instructions

01

STEP



Site preparation: straighten and clean each rebar before proceeding.

02

STEP



Mark each bar at a distance equal to half a RepairGrip sleeve from the bar end.

03

STEP



Put sleeves into the gauge supplied with the equipment and mark the gripping limit on each as shown above.

04

STEP

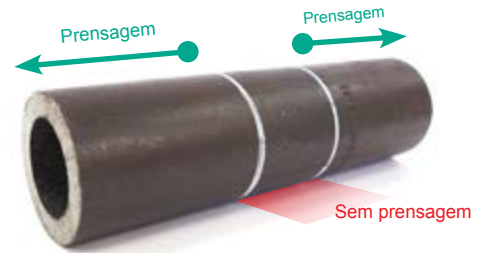

The central area of the sleeve should not be gripped. Gripping should be made from the limit towards the end of the sleeve.

05

STEP

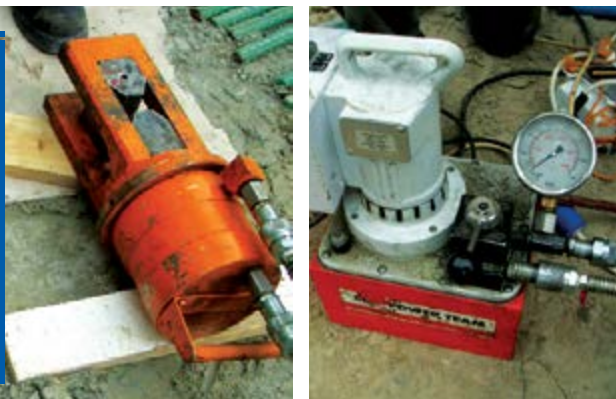

Prepare the hydraulic tool and set the adequate grip dies. Connect the power. In the case of using 380/440V motor, motor rotation can be corrected with the selector switch.

06

STEP



Insert the sleeve half way onto the continuation bar, using the mark on the bar as the engagement limit.

07

STEP



Start applying the required pressure on the RepairGrip sleeve.

08

STEP



Stop swaging when the pressure reaches the value specified in the [Operating Data table page 3](#).

09

STEP



Repeat the operation for each continuation bar that must be prepared.

10

STEP



At this stage, the second gripping limit should still be visible on sleeves. Caution, central area must not be swaged!

11

STEP



Pre-position connecting bars

12

STEP



Repeat swaging operation beyond the mark and at the required pressure to complete splicing operation.

## Some Major References



MRT - Blue line, Thailand



Socar Tower, Azerbaijan

Presença comercial em mais de 55 países



**CENTRAL - TAILANDIA**  
**Dextra Manufacturing Co., Ltd.**  
 Tel: (66) 2 021 3800  
 Fax: (66) 2 328 0374  
 E-mail: thailand@dextragroup.com



**INDIA**  
**Dextra India Pvt. Ltd.**  
 Tel: (91) 22 2838 6294 / 22 2839 2694  
 Fax: (91) 22 2839 2674  
 E-mail: india@dextragroup.com



**CHINA**  
**Dextra Building Products (Guangdong) Co., Ltd.**  
 Tel: (86) 20 2261 9901  
 Fax: (86) 20 2261 9902  
 E-mail: china@dextragroup.com



**HONG KONG**  
**Dextra Pacific Ltd.**  
 Tel: (852) 2845 7766 / 2511 8236  
 Fax: (852) 2586 1656 / 2519 0852  
 E-mail: dplbuilding@dextragroup.com



**MEDIO ORIENTE**  
**Dextra Middle-East FZE**  
 Tel: (971) 4886 5620  
 Fax: (971) 4886 5621  
 E-mail: middleeast@dextragroup.com



**EUROPA**  
**Dextra Europe SARL**  
 Tel: (33) 1 45 53 70 82  
 Fax: (33) 1 47 04 28 97  
 E-mail: europe@dextragroup.com



**AMÉRICA DEL NORTE**  
**Dextra America Inc.**  
 Tel: (1) 805 915 4734 / 818 261 5166  
 E-mail: america@dextragroup.com



**BRASIL**  
**Dextra do Brasil**  
 Tel: (55) 11 5505 2475  
 Fax: (55) 11 5505 2475  
 E-mail: brasil@dextragroup.com



**AMÉRICA LATINA**  
**Dextra Latam**  
 Tel: (507) 6454 8100 / (507) 831 1442  
 E-mail: latam@dextragroup.com



**Dextra**

[www.dextragroup.com](http://www.dextragroup.com)